

D16 Conditioned Seed Dryer SD-5016

The SD-5016 Conditioned Seed Dryer is a meticulously engineered solution tailored for the precise and controlled drying of vegetable and hemp seed lots. This state-of-the-art machine is ideally suited for commercial processing plants, where preserving seed quality and maximizing efficiency are paramount.

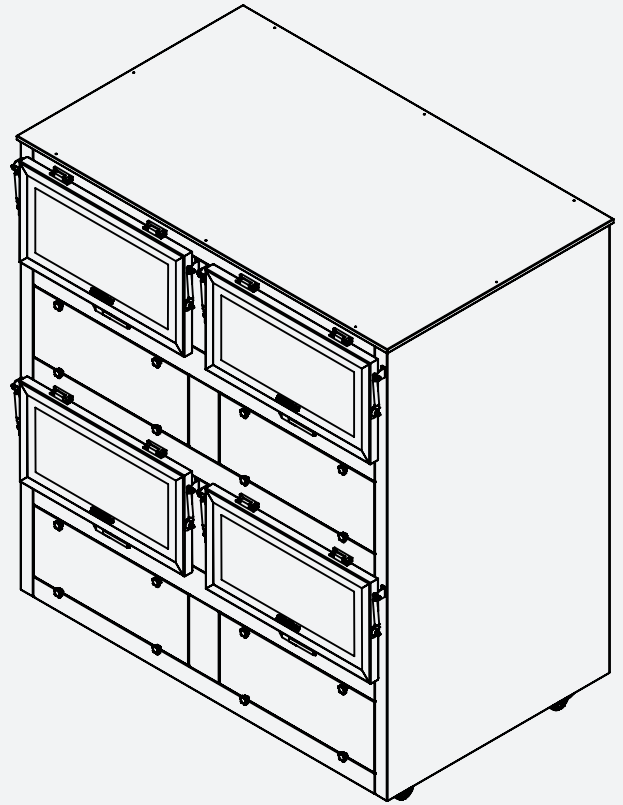

Key Features:

Ample Capacity: This dryer boasts an impressive capacity, accommodating up to 16 baskets, making it perfectly suited for handling large seed batches efficiently and effectively.

Dual Sections: To enhance operational flexibility, the machine is ingeniously divided into two independent sections, each equipped with 8 baskets. This design allows for separate operation of the sections, providing versatility in seed drying processes.

Preserving Seed Quality: The SD-5016 is equipped with automatic and reproducible drying processes, ensuring that the quality of your valuable seeds is preserved throughout the drying cycle. Additionally, these processes can be conveniently stored as recipes for future use, simplifying operations...and more.





D16 CONDITIONED SEED DRYER SD-5016



Capacity:

16 Basket with each 41 L
1-12,5 kg seeds/ basket

Dimensions:

2080 x 1330 x 2340 mm (LxWxH)

Water Connections:

Drain connection 32 mm

Noise emission:

± 75 dB(A) (measured without product)

Materials:

Stainless steel 304 Cr-Ni

Electrical connection:

380 - 400 V (± 5%), 3 phases + 0 and ground,
50 / 60 Hz (other values available on request)
Max. power consumption: 13 kW
Connection value: 32 A (slow blow)

Finishing:



Weight:

Net: ± 820kg
With packaging ± 940kg

Including:

16 x Basket

Optional:

- Ozon
- UV